

MOVEX®

MEX AA

Telescopic local extractor for extraction of fumes from atomic absorption processes

The MEX AA available in either round $\varnothing 10''$ (AAR) or rectangular 19"x10" (AAF) hood design is especially developed to take care of polluted air at a high temperature e.g. from an atomic absorption unit. The hood and all components that are at risk of coming into contact with hot air are made from stainless steel EN 1.4404, (316 L). The wall bracket is made from powder coated mild sheet steel. The vertical telescopic movement is 17".

The extractor is standard designed for wall mounting. The wall bracket is also adjustable horizontally. As an option a ceiling mounting bracket can be supplied.

For connection to the ventilation duct a 5 feet long flexible hose, with a maximum temperature resistance of 480 °F, is delivered with the extractor.

The telescopic movement is created by two sliding rings made of teflon for heat resistance and a locking device to ensure that the hood stays in the intended vertical position.



Movex also offers a range of fans, accessories and automatic control devices for our local extractors.

LOCAL EXTRACTOR
Pure advantage

Wall mounting

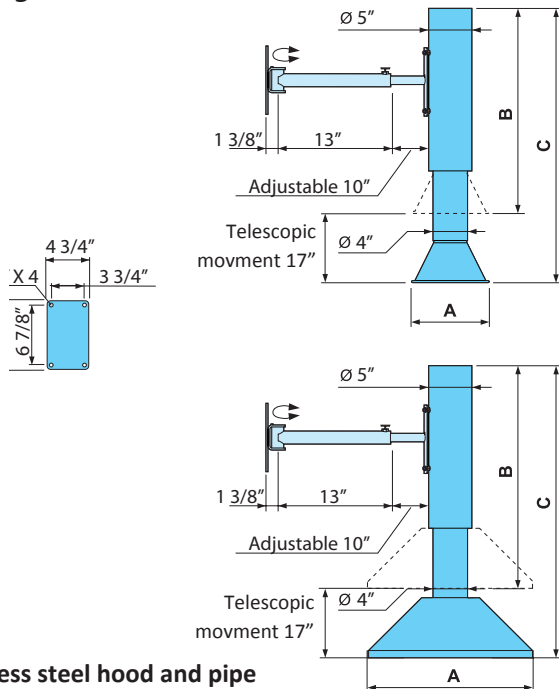

MEX AA stainless steel hood and pipe

Part. nr.	A inch	B inch	C inch
MEX AAR	∅ 10	25	42
MEX AAF	19 x 10	25	42

Ceiling mounting

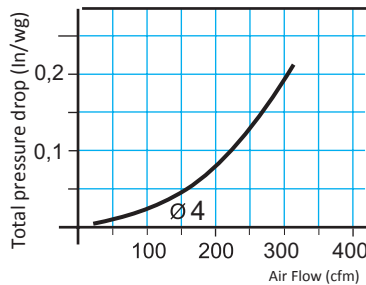
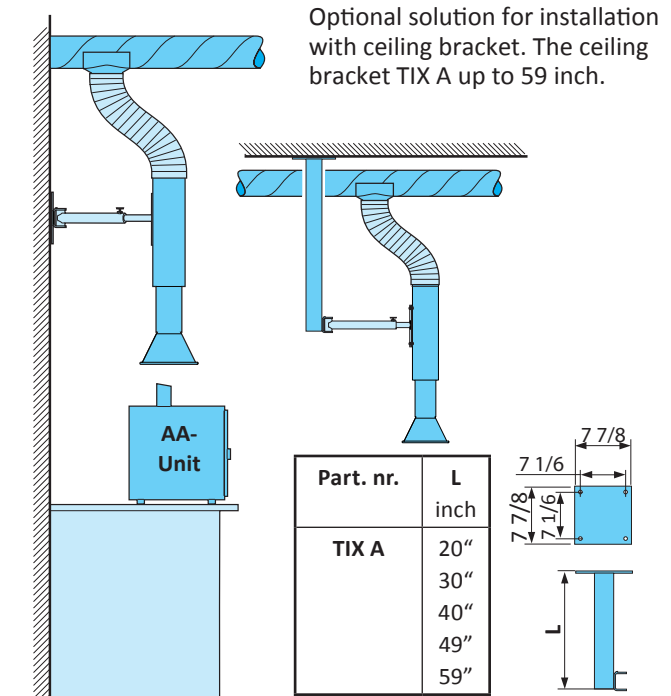

To avoid damage and other inconveniences on material further down the airstream it is recommended to extract a proportionately large volume of ambient room air to reduce the temperature of the extracted air.

Example - Air from the atomic absorption unit 20 cfm at 1800°F
 - Room air 140 cfm at 70°F
 - Mixed air (extracted air) 160 cfm at ~200°F

Tube and hoods

MEX AA is made from stainless steel EN 1.4404, (316 L). The wall bracket is white powder-coated mild steel.

Flexible hose

The hose is made from an outer and inner layer of aluminum with a supporting layer of polyester and spring steel coil. Length 5 feet including 2 clamps.

Delivery

For easy installation, the arm is delivered fully assembled. Wall bracket model is standard. The ceiling brackets are optional.

Flexible hose

Material Aluminium, polyester
 Temperature range -20°F to +480°F
 Dimension ∅ 5"

Sliding lining

Material PTFE, adjustable friction.
 Temperature range -20°F to +570°F

Other information

Surface treatment of mild steel components..... White powder coating
 Total weight..... 15 lb

MOVEX® INC.

104 Commerce Drive, Suite C,
 Northampton, PA 18067, USA
 Tel: 610-440-0478 Fax: 610-440-0480
 www.movexinc.com email: info@movexinc.com